

LITTLE DAVID

LABELER LX-500P

LABEL SOLUTION FOR THE REAL WORLD



Continuing the tradition of functional labeling for the real world, Loveshaw is proud to release The Little David® LX-500P.

The easy to use LX-500P is a compact and versatile label applicator that can be oriented for top, side or bottom labeling.



FEATURES OF THE LX-500P INCLUDE:

- Wipe-On Label Applicator
- Drive Roller-Free Patent-Pending Feed System
- Accurate and Reliable Brushless Servo Motor
- Instantaneous Setting changes
- Durable Stainless Steel Peel Blade
- Easy-to-Read LED Text Display
- Built-In Diagnostics

PERFORMANCE & DESIGN FEATURES:

LX-500P can be oriented for top, side or bottom labeling



Servo-controlled label dispensing ensures wrinkle-free application



Control Module makes adjustments quickly with a rotary shuttle control



LITTLE DAVID

LX-500P

SPECIFICATIONS:

LABELER

Max. Line Speed: 120 fpm (61 cm/s); Min. Line Speed: 10 fpm (5 cm/s)
Max. Label Width: 5" (12.7 cm); Min. Label Width: 1" (25.4 mm)
Max. Label Length: 8" (20.3 cm); Min. Label Length: 1" (25.4 mm)
Accuracy: $\pm 0.0625"$ (± 1.58 mm)
Supply Roll OD: 14" (35.5 cm)
Supply Roll Capacity: 14" (355.6 mm)

ELECTRICAL

AC Voltage Supply
Nominal: 100 - 240 VAC, 1.6 A, 50/60 Hz
Minimum: 90 VAC, 47 Hz; Maximum: 264 VAC, 63 Hz

Product Detector
Nominal: low 0-3 VDC; high 3-5 VDC
Minimum: 0 VDC; Maximum: 24 VDC

Product Detector Pulse
Nominal 10 mS; Minimum 1 mS

Width
Maximum infinite

Warning Tower
Nominal: 0 and 24 VDC, 1 Amp sinking
Minimum: 0 VDC, 0 mA; Maximum: 24 VDC, 1.5 Amps sinking

GENERAL

Temperature: 41° to 104° F (5° to 40° C)
Humidity: 10 to 85% RH, non-condensing
Dimensions: (with yoke) 32" L x 23" D x 19" H
(812.8 mm x 584.2 mm x 482.6 cm)
Weight: 38 lbs. (17.3 kg)
(includes yoke, not stand)
Certifications: CE, CSA, FCC Approved, Listed (UL 60950)

MACHINE DIMENSIONS:

19" (48.26cm) high
32" (81.8cm) long
23" (58.42cm) wide

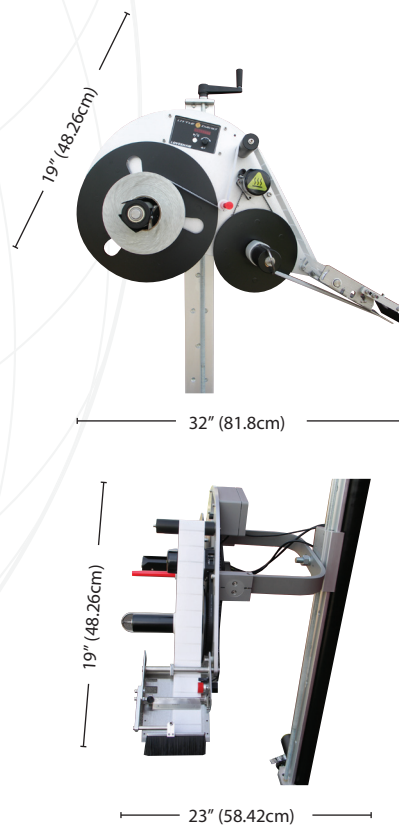

LX-500P shown here
with optional stand



LOVESHAW

2206 East Turnpike
P.O. Box 83
South Canaan, PA 18459
Tel: (570) 937-4921 Fax: (570) 937-3229
Toll Free: (800) 572-3434

LOVESHAW Europe

Unit 9 Brunel Gate
West Portway Industrial Estate
Andover, Hampshire, England SP10 3SL
Tel: (1264) 357511 Fax: (1264) 355963